

## 19. Console Box

### A: REMOVAL

1) Disconnect the ground cable from battery. <Ref. to NT-5, BATTERY, NOTE, Note.>

**NOTE:**

- For the 12 volt engine restart battery of HEV model, disconnect the ground terminal from 12V engine restart battery sensor.
- On CVT models, shift the select lever into "D" before disconnecting the battery ground cable.

2) Remove the console box assembly.

- (1) Release the claws, and then remove the boot - hand brake.

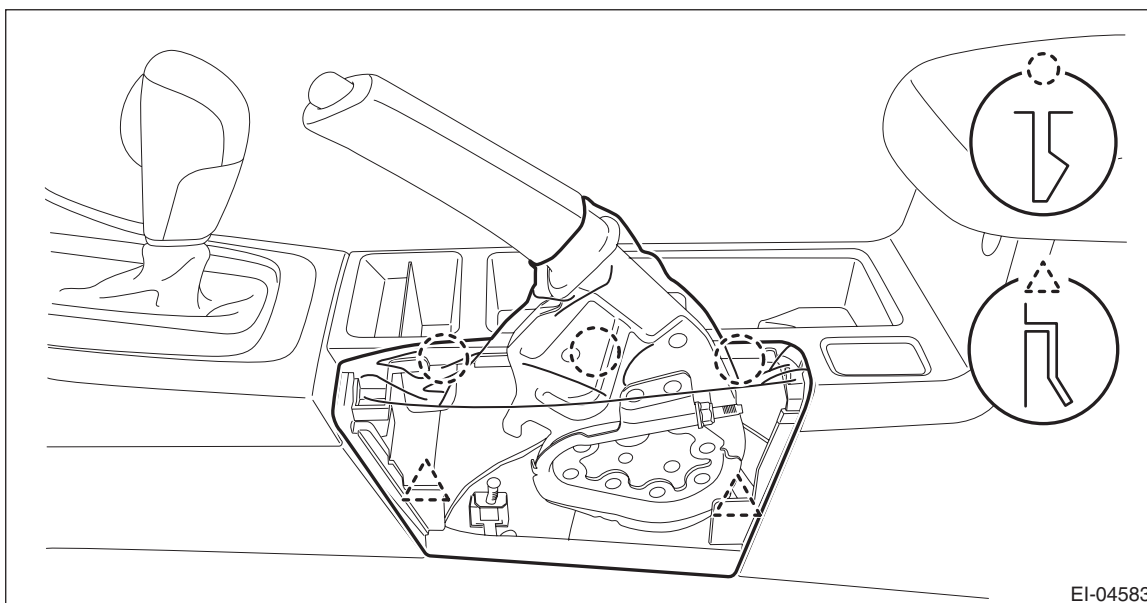

(2) Move the seat forward, and remove the bolts after detaching the left and right caps.

(3) Remove the screws and clips, disconnect the harness connector and remove the console box assembly.

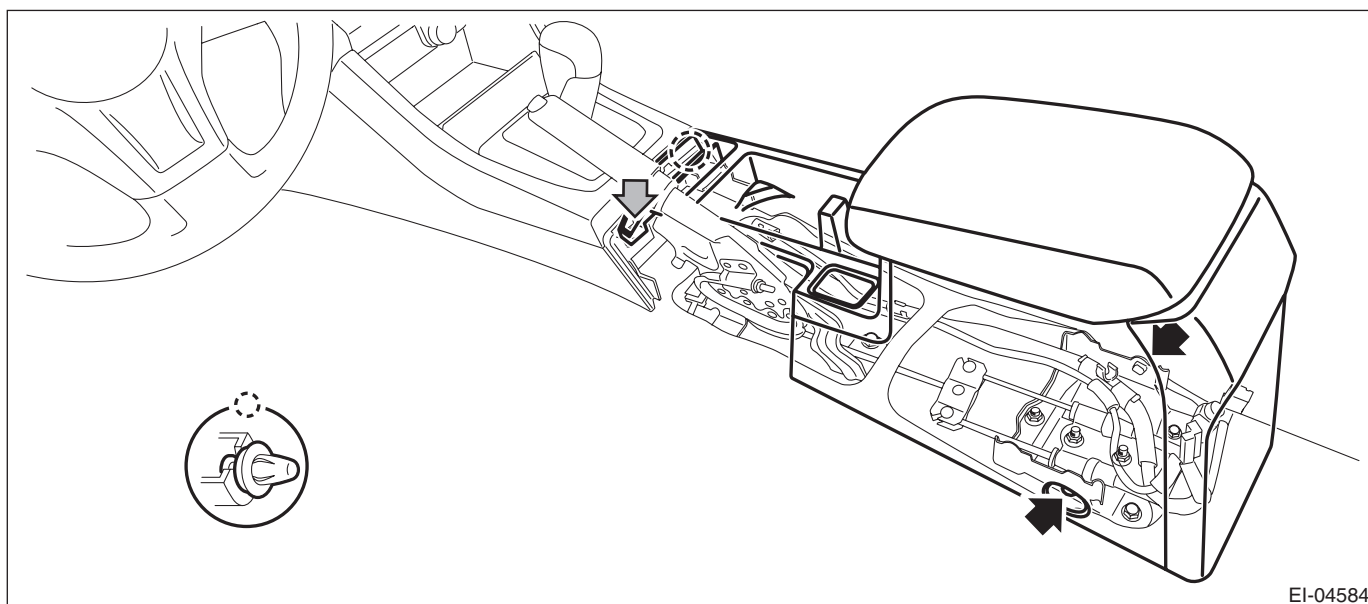

# Console Box

## EXTERIOR/INTERIOR TRIM

3) Remove the cover - shift lever.

(1) Remove the shift knob. (MT model)

(2) Release the clips and claws, then pull up the cover - shift lever.

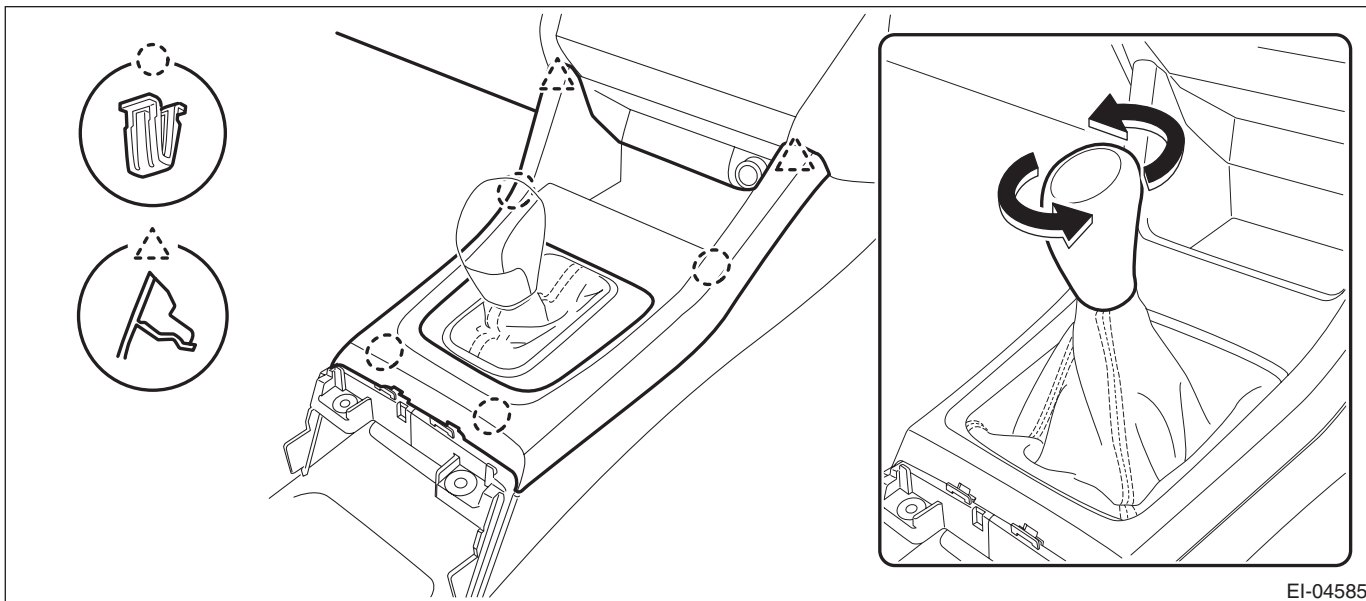

4) Remove the left and right panel center LWR.

(1) Remove the screws and clips.

(2) Release the claws, and then pull the panel center LWR to remove.

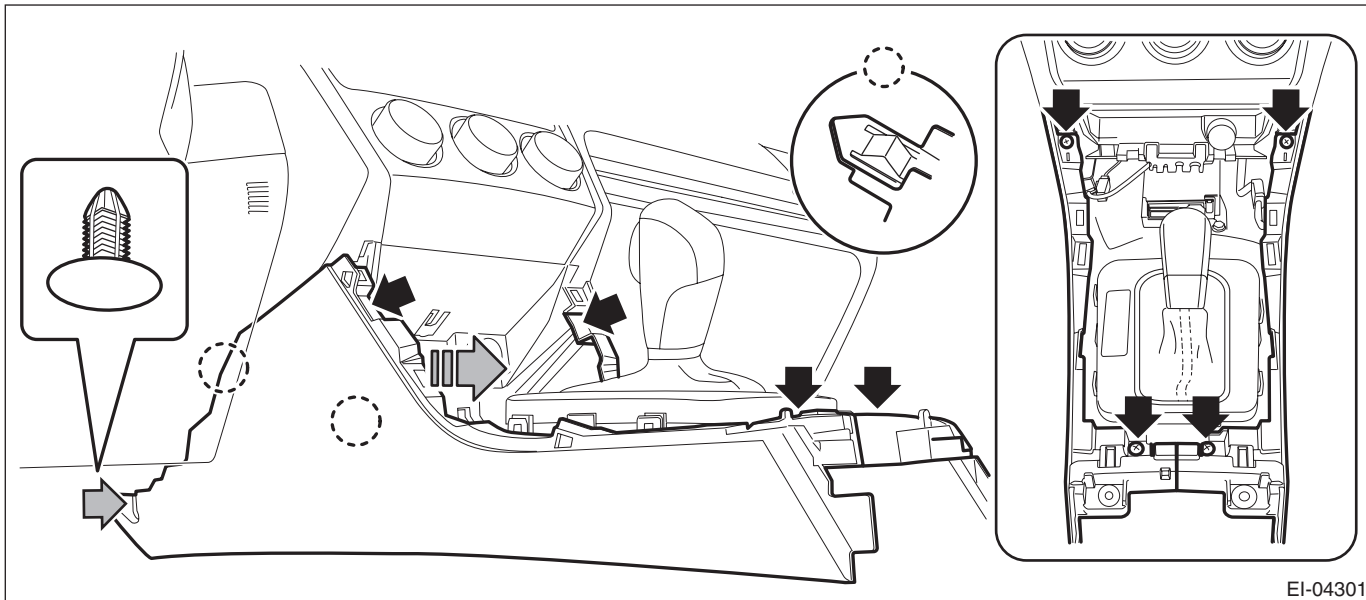

## B: INSTALLATION

Install each part in the reverse order of removal.

**Tightening torque:**

**6.5 N·m (0.66 kgf·m, 4.8 ft·lb)**